

INBOARD PROFILE

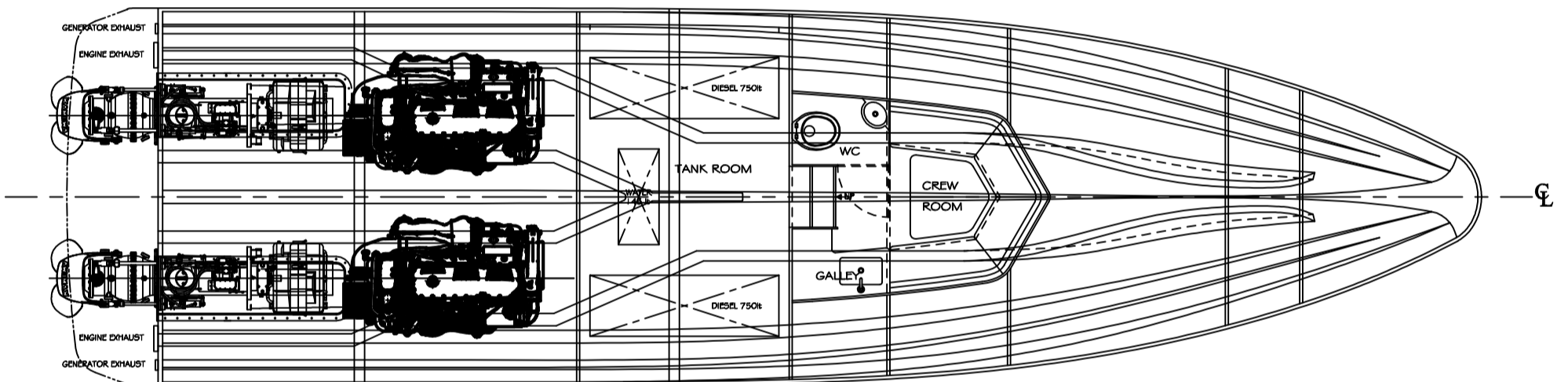

LOWER DECK PLAN

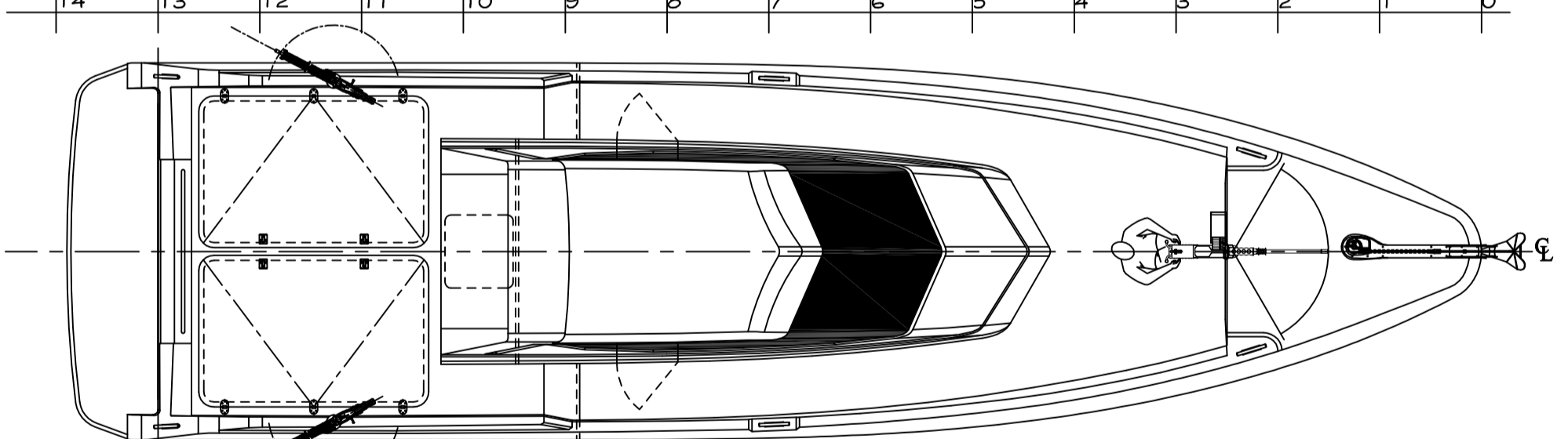

MAIN DECK PLAN

PRINCIPAL CHARACTERISTICS

L. O. A. (inc. platform)	13.90 M
L. O. A. (moulded)	13.00 M
L. W. L.	11.30 M
BEAM (moulded)	3.71 M
DRAFT (moulded)	0.77 M
SPEED Max. est.	50+ knots
DISP. (full) est.	13,000 kg
DIESEL	1500 lt
WATER	150 lt
ENGINES	2 X 1000hp CAT C12.9

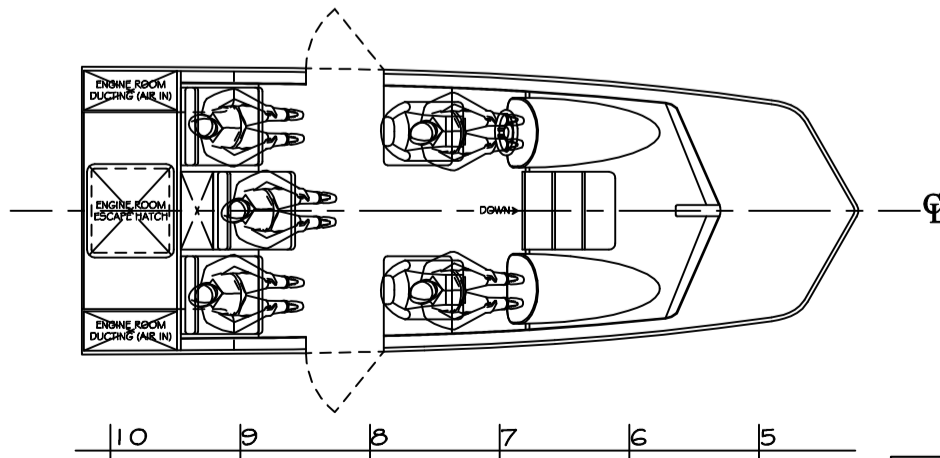

WHEELHOUSE

		PROJECT		1.3MT INTERCEPTOR CRAFT	
		TITLE		PROPOSED GENERAL ARRANGEMENT	
FIRST ISSUE	0	ART	JZE	DATE	3-7-16
REVISIONS	NOI	DATE	DRN	CHKD	APP.
<small>THIS DRAWING AND ITS CONTENTS ARE THE SOLE PROPERTY OF RIVIERA. UNLESS OTHERWISE STATED, ALL RIGHTS ARE RESERVED. NO PART OF THIS DRAWING OR ANY OF ITS CONTENTS MAY BE REPRODUCED, COPIED, OR USED IN ANY MANNER WITHOUT PRIOR WRITTEN PERMISSION.</small>					