

Length : 9.50 m  
 Width : 4.25 m  
 Depth  
 Shallow End : 1.10 m  
 Deep End : 2.10 m

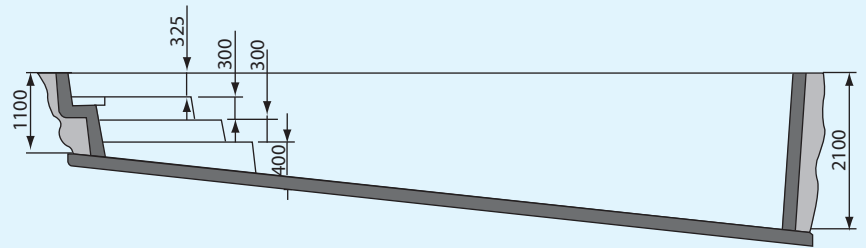

### Filtration Plant

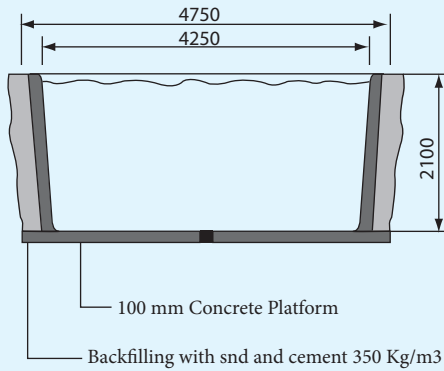
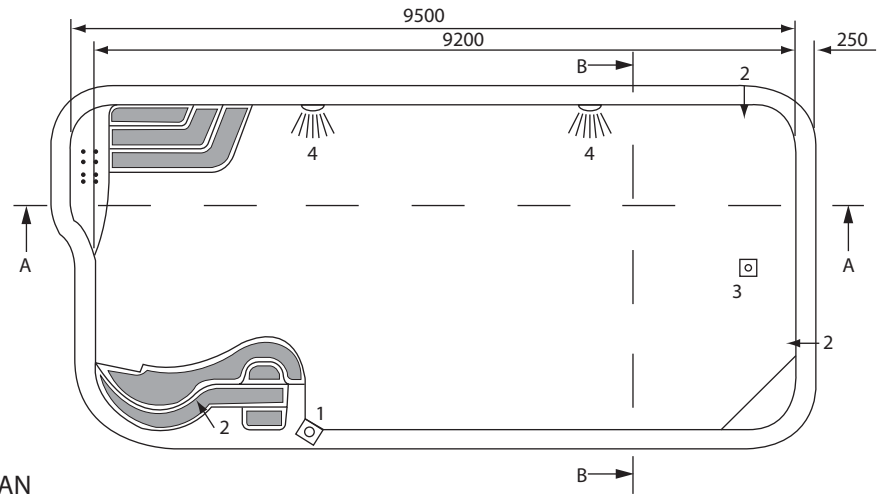
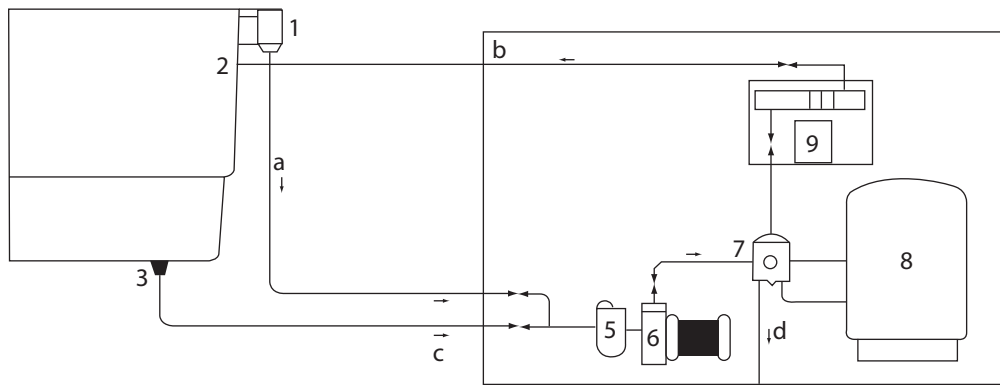

### Electrical Connections

1 no. 1 hp pump  
 2 nos. 300 W 12 V lights  
 1 no. pool heater 24 kw (opti.)  
 Pump and heater protected by dry running protection  
 System protected by 30 MA ELCB and MCB

### Legends

- |                      |                                   |
|----------------------|-----------------------------------|
| 1. Surface skimmer   | 8. Filtertank                     |
| 2. Return inlet      | 9. Control panel (optional)       |
| 3. Main drain        | 10. Pool heater 24 kw (optional)  |
| 4. Under water light | a. from skimmer                   |
| 5. Prefilter         | b. return to pool                 |
| 6. Pump              | c. from maindrain                 |
| 7. Multiport valve   | d. to waste (backwash & emptying) |

Volume : 60.00 cbm  
 Area : 35.00 sqm

Pump : 1hp. 14 cbm/hr  
 Flow : 15 cbm/hr  
 Turnover rate : 4.00 hours