

Length : 9.00 m
 Width : 4.50 m
 Depth
 Shallow End : 1.20 m
 Deep End : 1.80 m

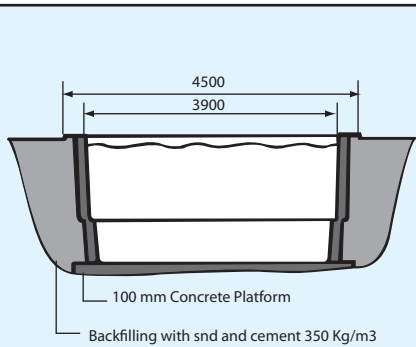

SECTION B-B

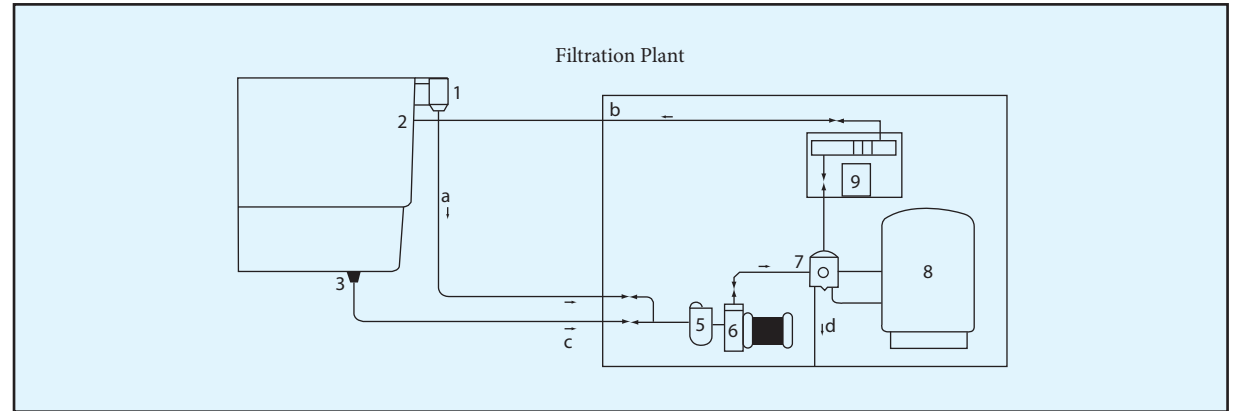
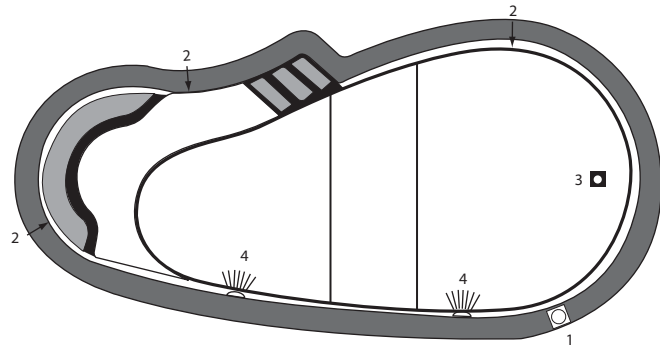
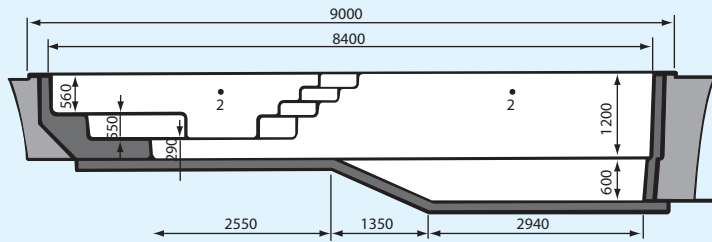

SECTION A-A

Electrical Connections

- 1 no. 1 hp pump
- 2 nos. 300 W 12 V lights
- 1 no. pool heater 24 kw (opti.)
- Pump and heater protected by dry running protection
- System protected by 30 MA ELCB and MCB

Legends

- | | |
|----------------------|-----------------------------------|
| 1. Surface skimmer | 8. Filtertank |
| 2. Return inlet | 9. Control panel (optional) |
| 3. Main drain | 10. Pool heater 24 kw (optional) |
| 4. Under water light | a. from skimmer |
| 5. Prefilter | b. return to pool |
| 6. Pump | c. from maindrain |
| 7. Multiport valve | d. to waste (backwash & emptying) |

Volume : 42 cbm
 Area : 29 sqm

Pump : 1hp. 14 cbm/hr
 Flow : 15 cbm/hr
 Turnover rate : 3.00 hours